

Biological Networks Analysis

Introduction and Dijkstra's algorithm

Genome 559: Introduction to Statistical and
Computational Genomics

Elhanan Borenstein

A quick review

- **The clustering problem:**

- partition genes into distinct sets with high homogeneity and high separation

- **Hierarchical clustering algorithm:**

1. Assign each object to a separate cluster.
2. Regroup the pair of clusters with shortest distance.
3. Repeat 2 until there is a single cluster.

- Many possible distance metrics

- **K-mean clustering algorithm:**

1. Arbitrarily select k initial centers
2. Assign each element to the closest center
 - **Voronoi diagram**
3. Re-calculate centers (i.e., means)
4. Repeat 2 and 3 until termination condition reached

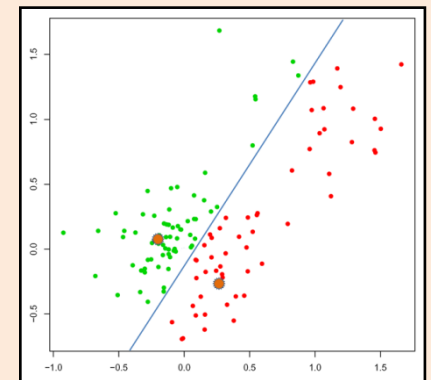
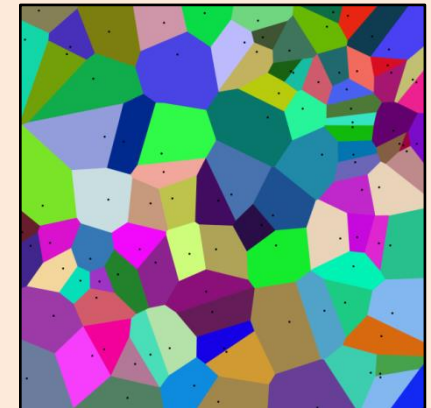
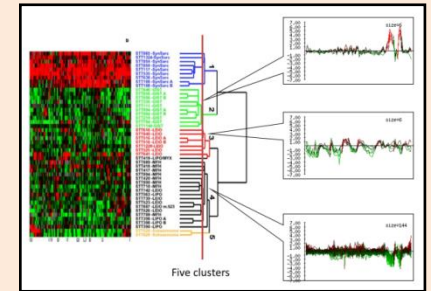

Biological networks

What is a network?

What networks are used in biology?

Why do we need networks (and network theory)?

How do we find the shortest path between two nodes?

Why we need networks (and systems biology)?



VS.



What is a network?

- A map of interactions or relationships
- A collection of **nodes** and **links (edges)**

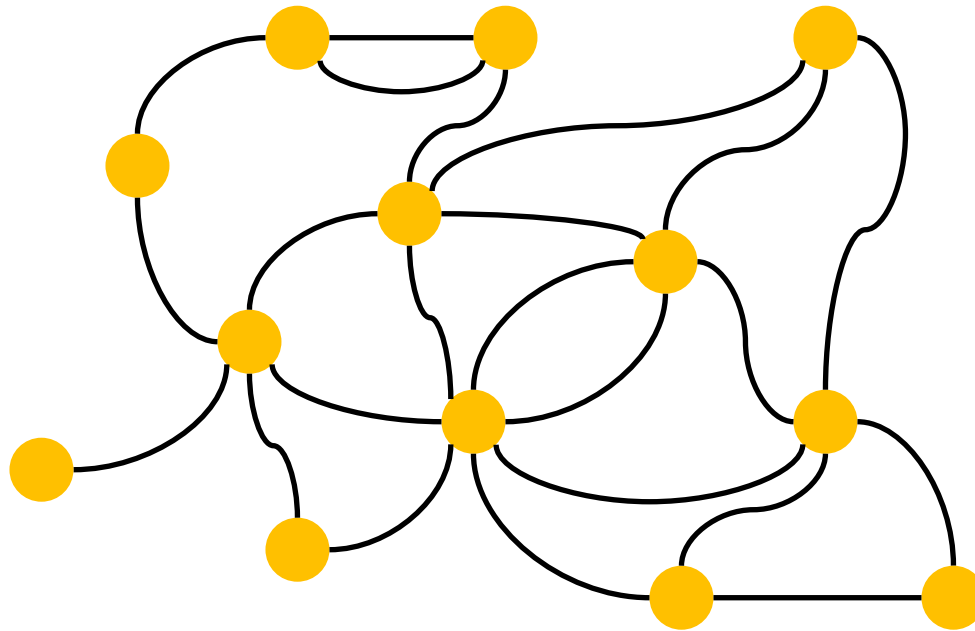

Networks vs. Graphs

Network theory

Social sciences
Biological sciences

Mostly 20th century

Modeling real-life
systems

Measuring
structure & topology

Graph theory

Computer science

Since 18th century!!!

Modeling abstract
systems

Solving “graph-
related” questions

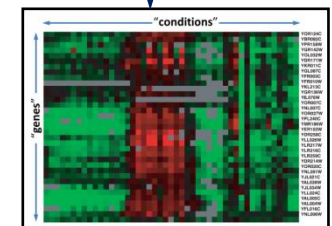
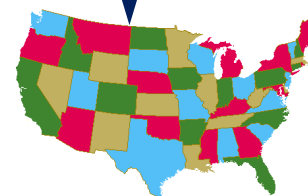

The Seven Bridges of Königsberg

- Published by **Leonhard Euler, 1736**
- Considered the first paper in graph theory

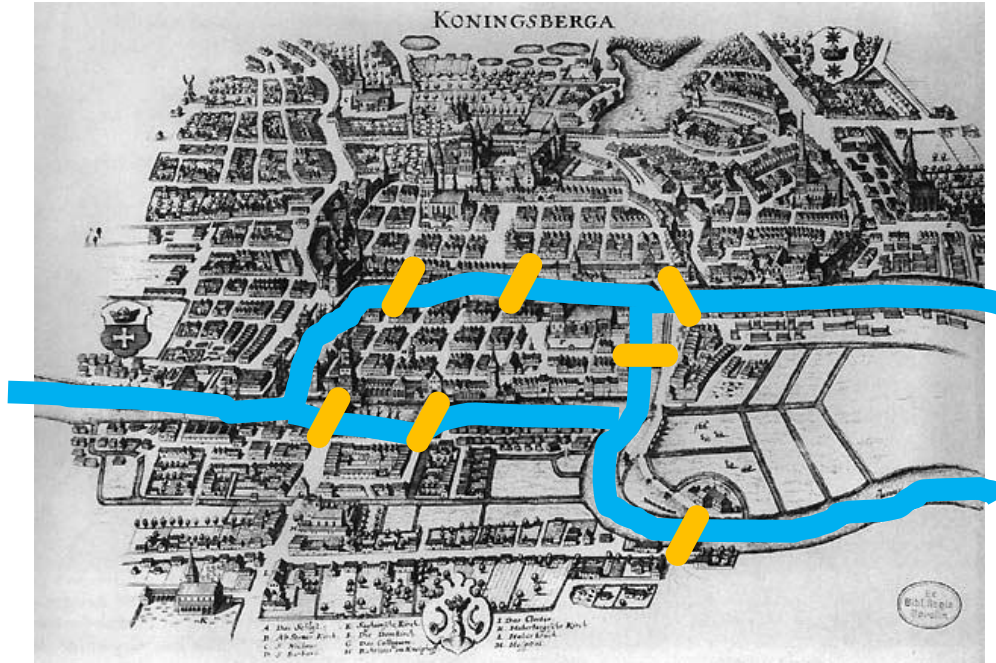

Leonhard Euler
1707 –1783

The Seven Bridges of Königsberg

- Published by **Leonhard Euler, 1736**
- Considered the first paper in graph theory

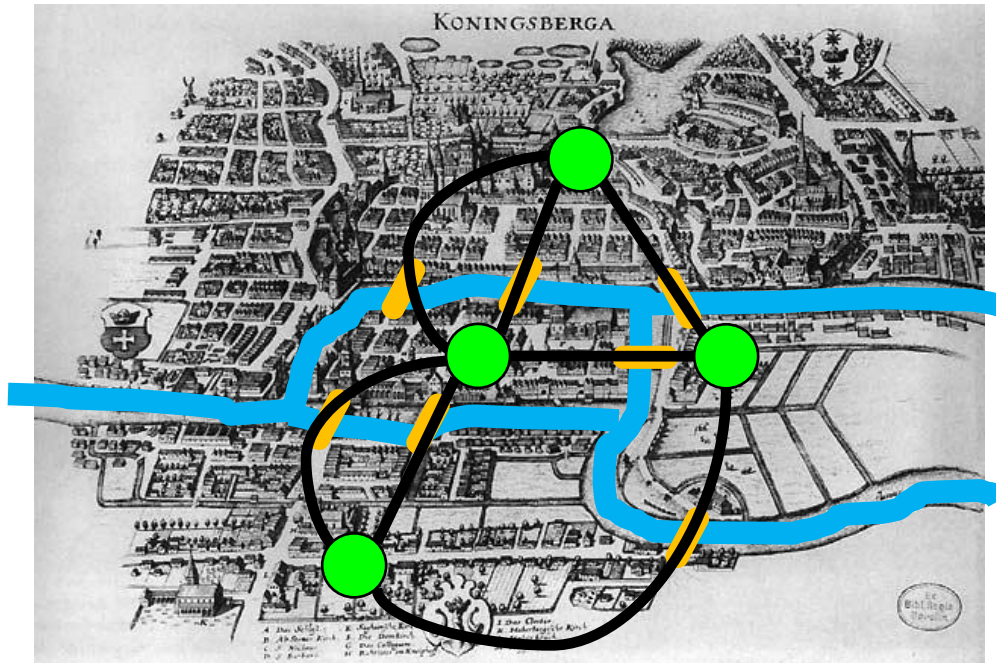

Leonhard Euler
1707 –1783

What is a network?

- A map of interactions or relationships
- A collection of **nodes** and **links (edges)**

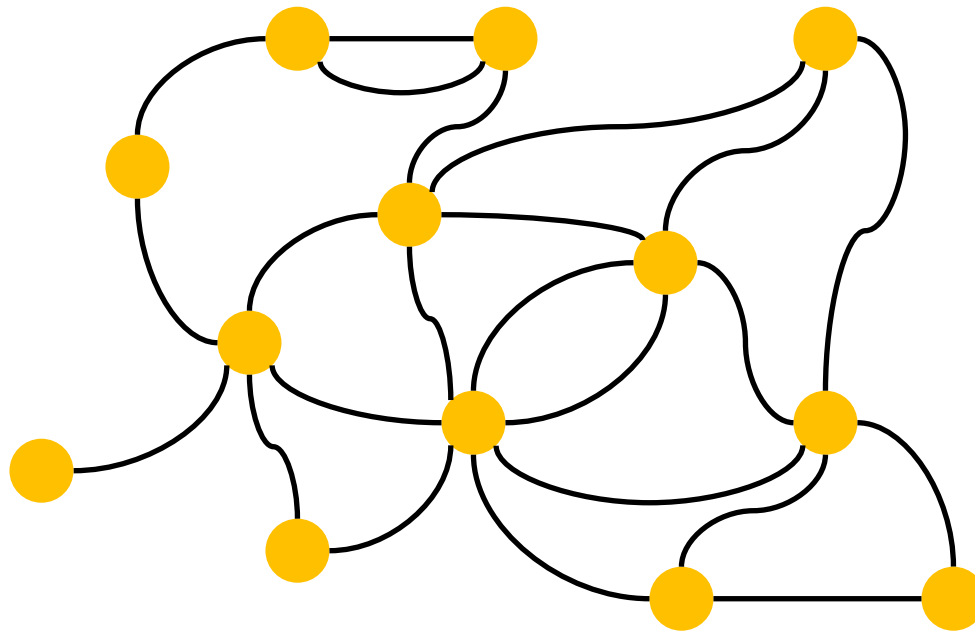

Types of networks

■ Edges:

- Directed/undirected
- Weighted/non-weighted
- (Simple-edges/Hyperedges)

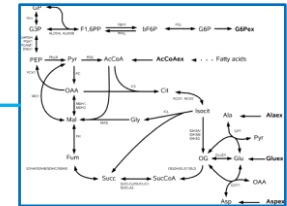
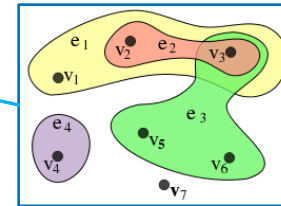
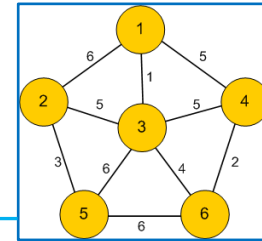
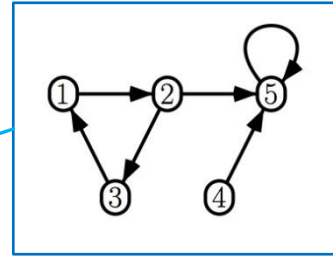

■ Special topologies:

- Directed Acyclic Graphs (DAG)
- Trees
- Bipartite networks

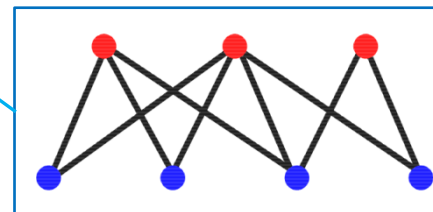
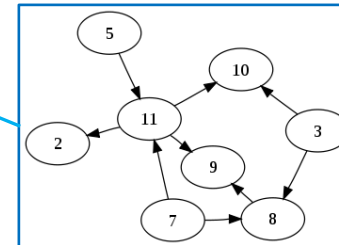
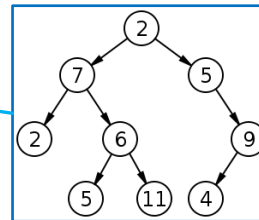

Transcriptional regulatory networks

- Reflect the cell's genetic regulatory circuitry
 - **Nodes:** transcription factors and genes;
 - **Edges:** from TF to the genes it regulates
 - Directed; weighted?; “almost” bipartite
- Derived through:
 - Chromatin IP
 - Microarrays
 - **Computationally**

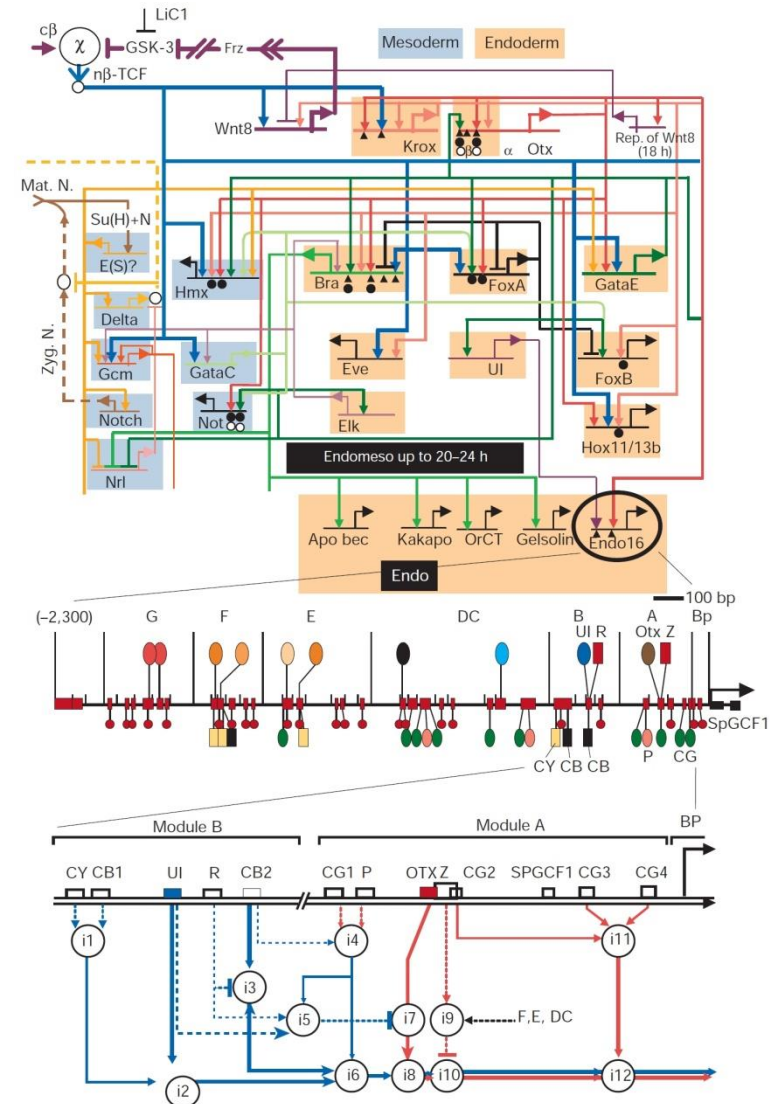

Metabolic networks

- Reflect the set of biochemical reactions in a cell
 - **Nodes:** metabolites
 - **Edges:** biochemical reactions
 - Directed; weighted?; hyperedges?
- Derived through:
 - Knowledge of biochemistry
 - Metabolic flux measurements
 - Homology?



S. Cerevisiae

1062 metabolites

1149 reactions

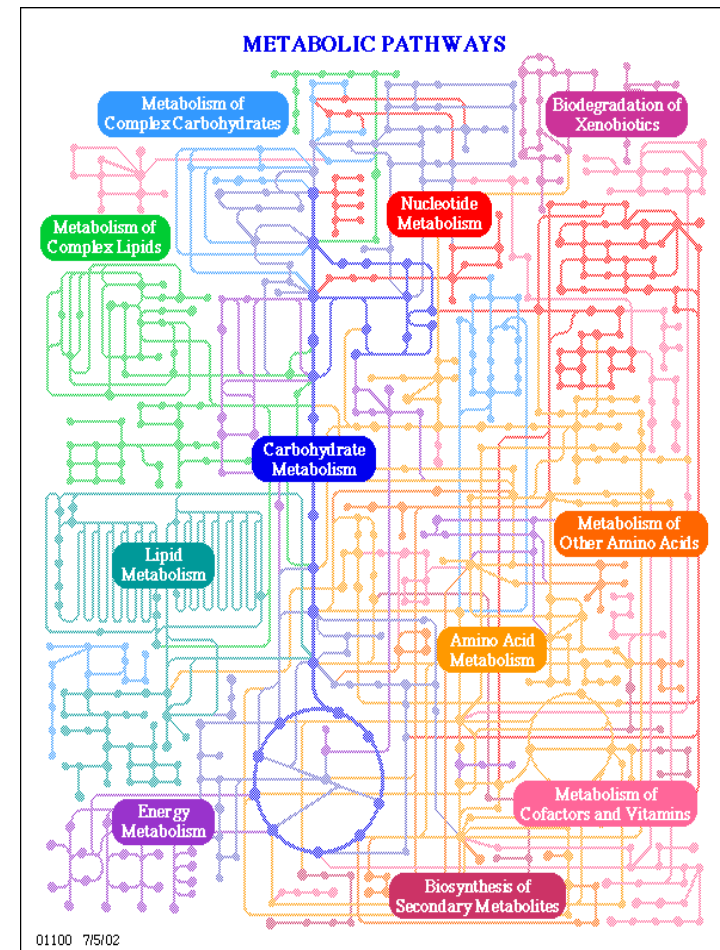

Protein-protein interaction (PPI) networks

- Reflect the cell's molecular interactions and signaling pathways (interactome)
 - **Nodes:** proteins
 - **Edges:** interactions(?)
 - Undirected
- High-throughput experiments:
 - Protein Complex-IP (Co-IP)
 - Yeast two-hybrid
 - Computationally

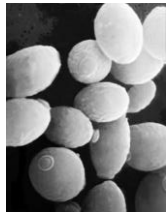

S. Cerevisiae

4389 proteins

14319 interactions

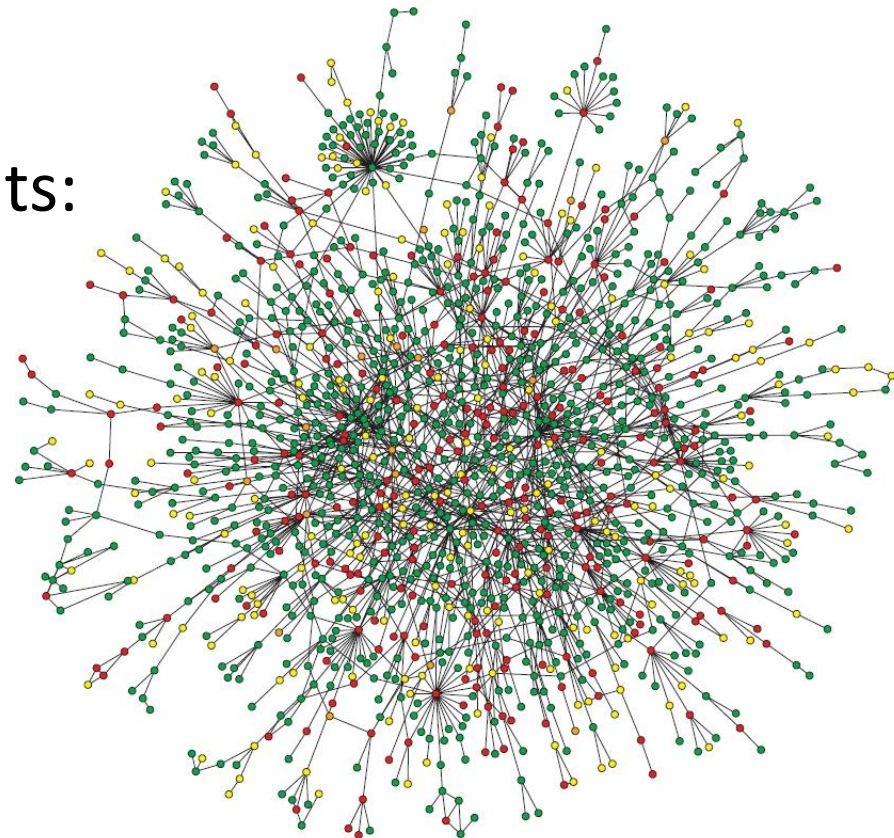

Other networks in biology/medicine

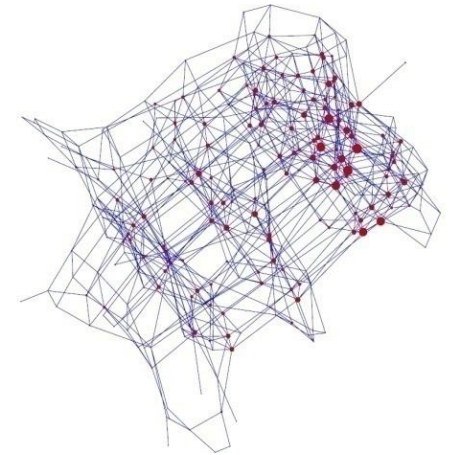
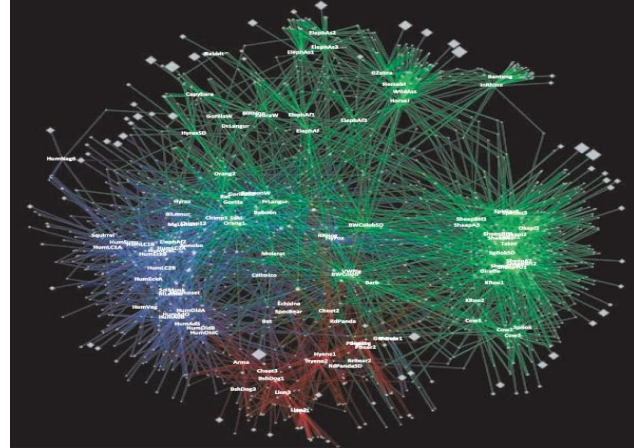
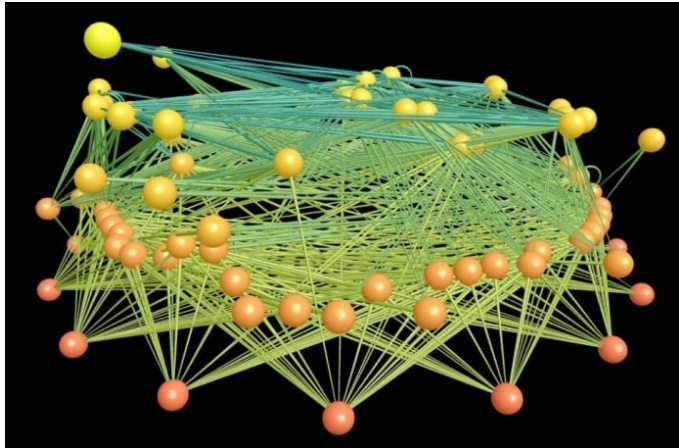
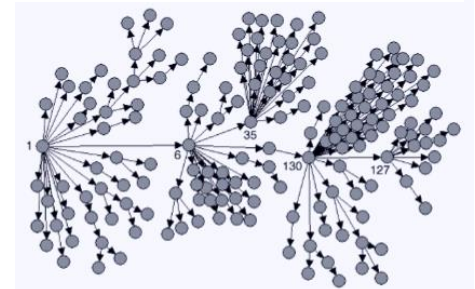
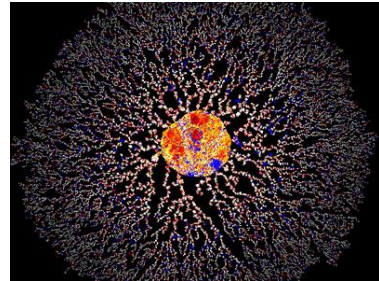
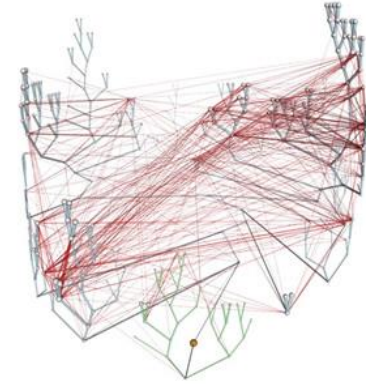
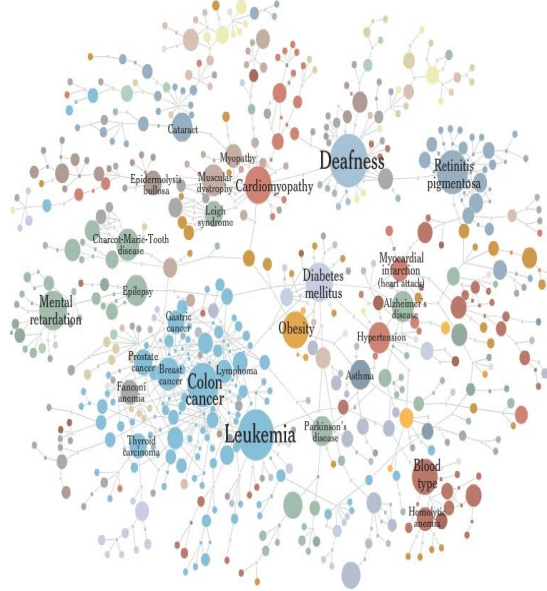
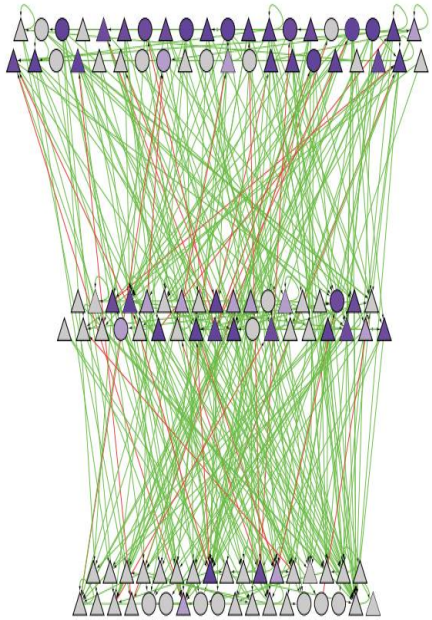

Non-biological networks

- **Computer related networks:**

- WWW; Internet backbone
- Communications and IP

- **Social networks:**

- Friendship (facebook; clubs)
- **Citations** / information flow
- Co-authorships (papers)
- Co-occurrence (movies; Jazz)

- **Transportation:**

- Highway systems; Airline routes

- **Electronic/Logic circuits**

- Many many more...

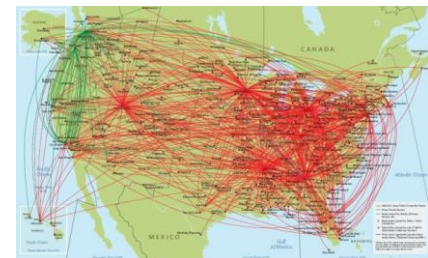
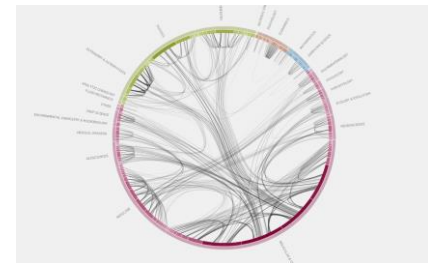
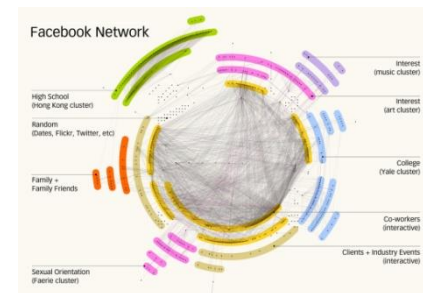
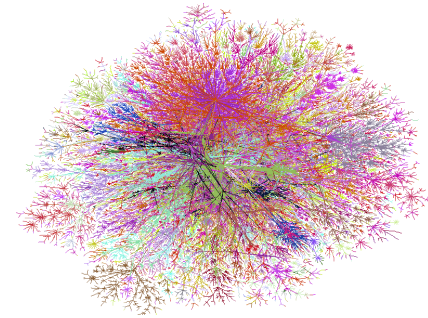

An Oscar Special: The Bacon Number Game



Tropic Thunder
(2008)

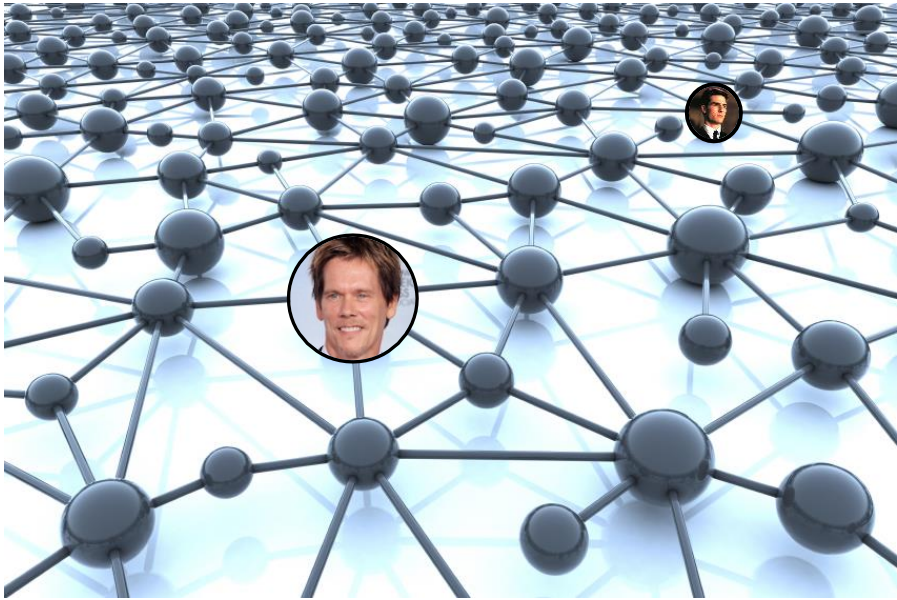

Tropic Thunder



Iron Man



Proof



Flatliners



Tom Cruise

Robert Downey Jr.

Gwyneth Paltrow

Hope Davis

Kevin Bacon



Tropic Thunder



Iron Man



Frost/Nixon



Tom Cruise

Robert Downey Jr.

Frank Langella

Kevin Bacon

The Paul Erdos Number Game

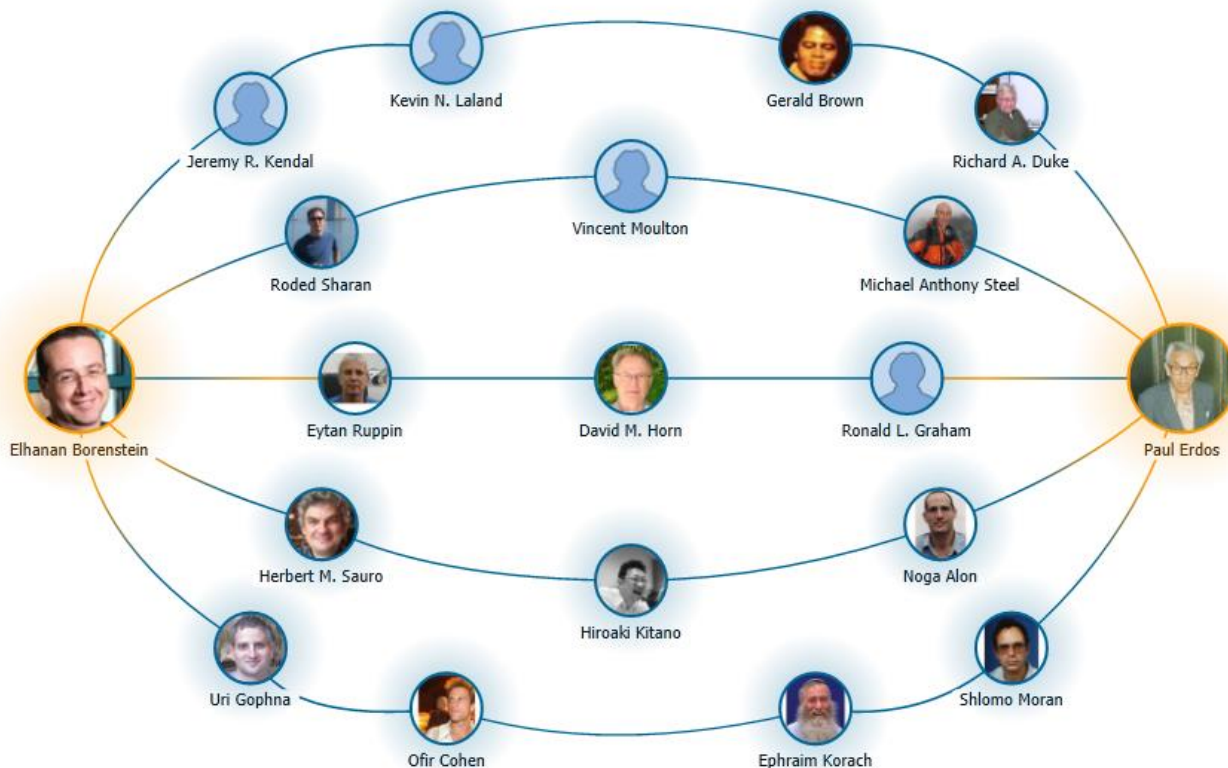

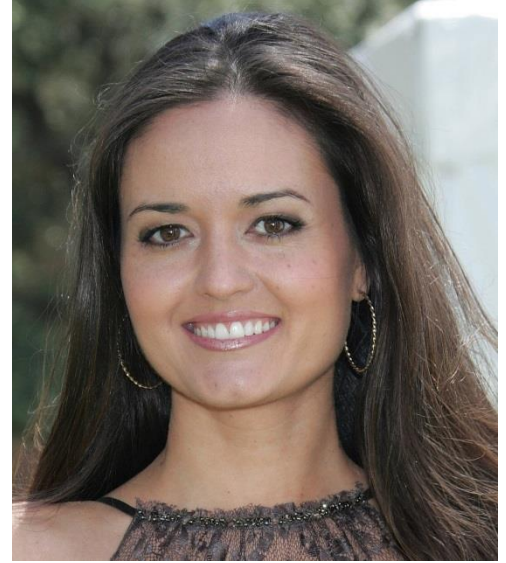
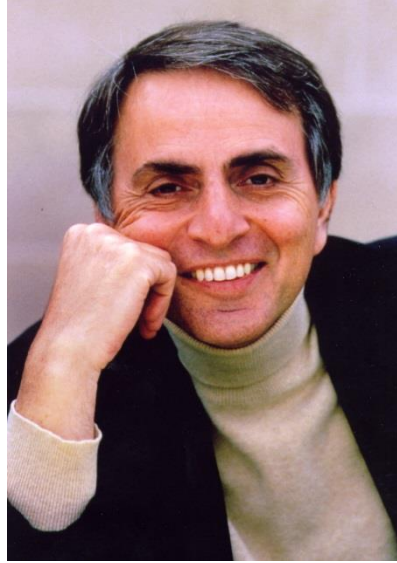
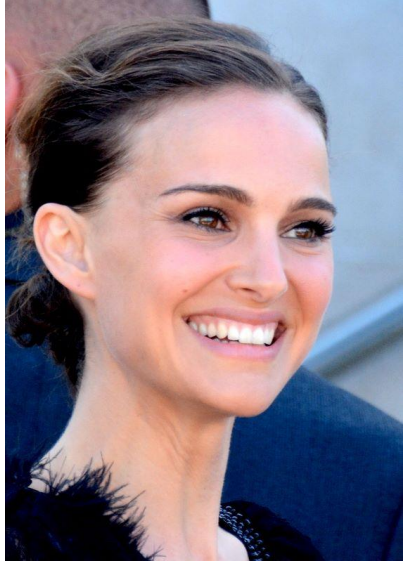



7

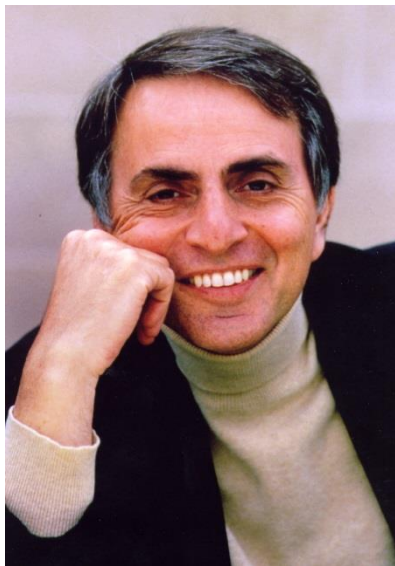

6

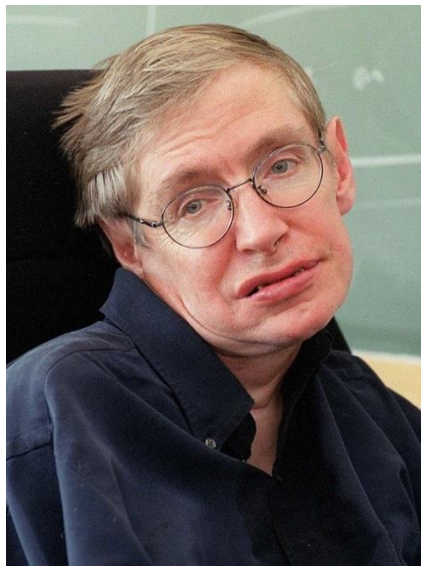

6



6

The shortest path problem

- Find the minimal number of “links” connecting node A to node B in an undirected network
 - How many friends between you and someone on FB (six degrees of separation, Erdős number, Kevin Bacon number)
 - How far apart are two genes in an interaction network
 - What is the shortest (and likely) infection path
- Find the shortest (cheapest) path between two nodes in a weighted directed graph
 - GPS; Google map

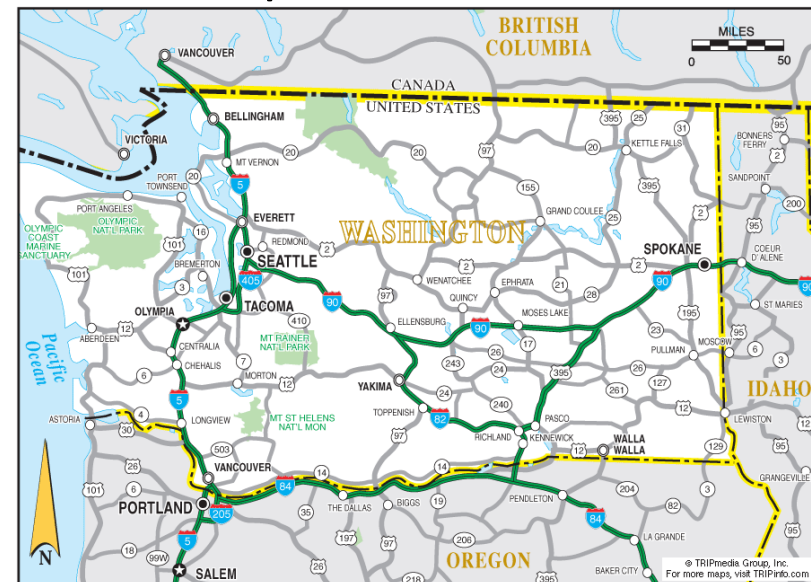

Dijkstra's Algorithm

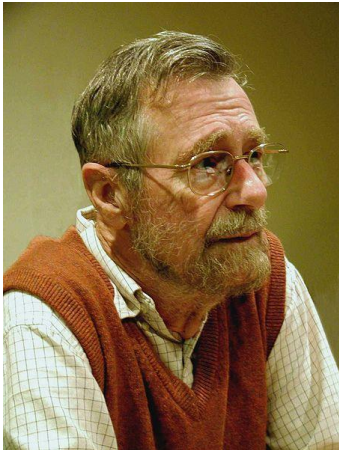

Edsger Wybe Dijkstra
1930 –2002

"Computer Science is no more about computers than astronomy is about telescopes."

Dijkstra's algorithm

- **Solves the single-source shortest path problem:**
 - Find the shortest path from a single source to **ALL** nodes in the network
 - Works on both **directed** and **undirected** networks
 - Works on both **weighted** and **non-weighted** networks
- **Approach:**
 - Iterative : maintain shortest path to each intermediate node
- **Greedy algorithm**
 - ... but still guaranteed to provide optimal solution !!

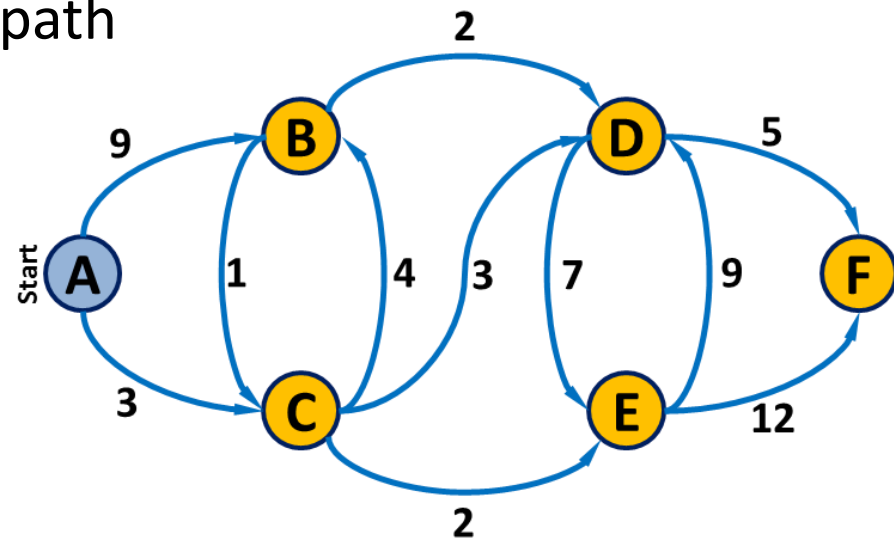

Dijkstra's algorithm

1. Initialize:

- i. Assign a distance value, D , to each node.
Set D to zero for *start* node and to infinity for all others.
- ii. Mark all nodes as unvisited.
- iii. Set *start* node as current node.

2. For each of the current node's unvisited neighbors:

- i. Calculate tentative distance, D^t , through current node.
- ii. If D^t smaller than D (previously recorded distance): $D \leftarrow D^t$
- iii. Mark current node as visited (note: shortest dist. found).

3. Set the unvisited node with the smallest distance as the next "current node" and continue from step 2.

4. Once all nodes are marked as visited, finish.

Dijkstra's algorithm

- A simple synthetic network

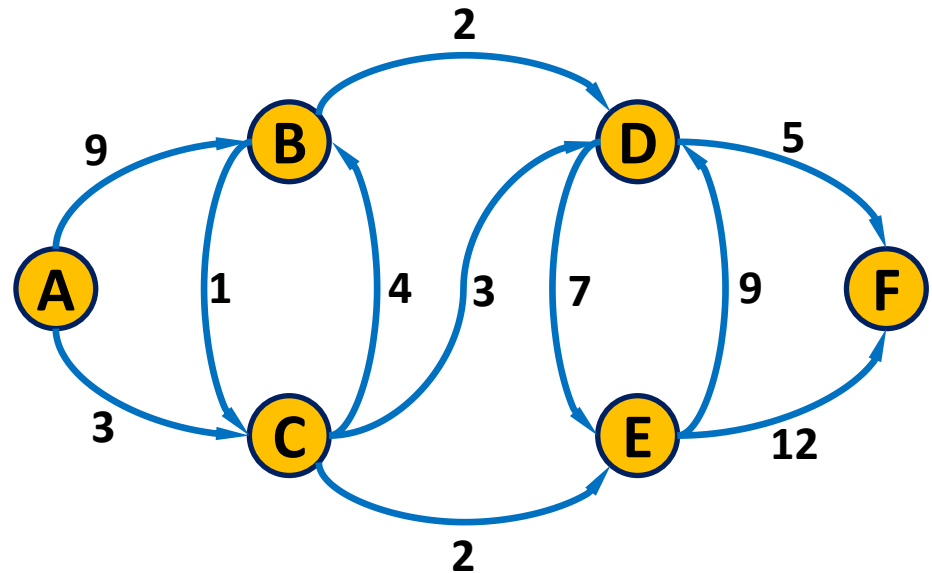

1. Initialize:

- Assign a distance value, D , to each node.
Set D to zero for *start* node and to infinity for all others.
- Mark all nodes as unvisited.
- Set *start* node as current node.

2. For each of the current node's unvisited neighbors:

- Calculate tentative distance, D^t , through current node.
- If D^t smaller than D (previously recorded distance): $D \leftarrow D^t$
- Mark current node as visited (note: shortest dist. found).

3. Set the unvisited node with the smallest distance as the next "current node" and continue from step 2.

4. Once all nodes are marked as visited, finish.

Dijkstra's algorithm

- Initialization
- Mark A (start) as current node

A	B	C	D	E	F
0	∞	∞	∞	∞	∞

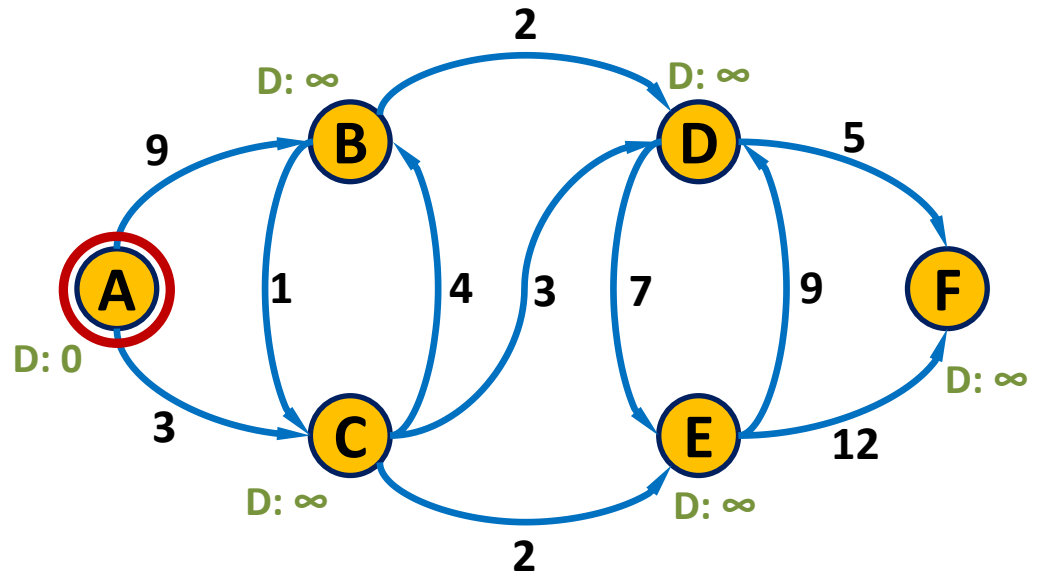

Dijkstra's algorithm

- Check unvisited neighbors of A

A	B	C	D	E	F
0	∞	∞	∞	∞	∞

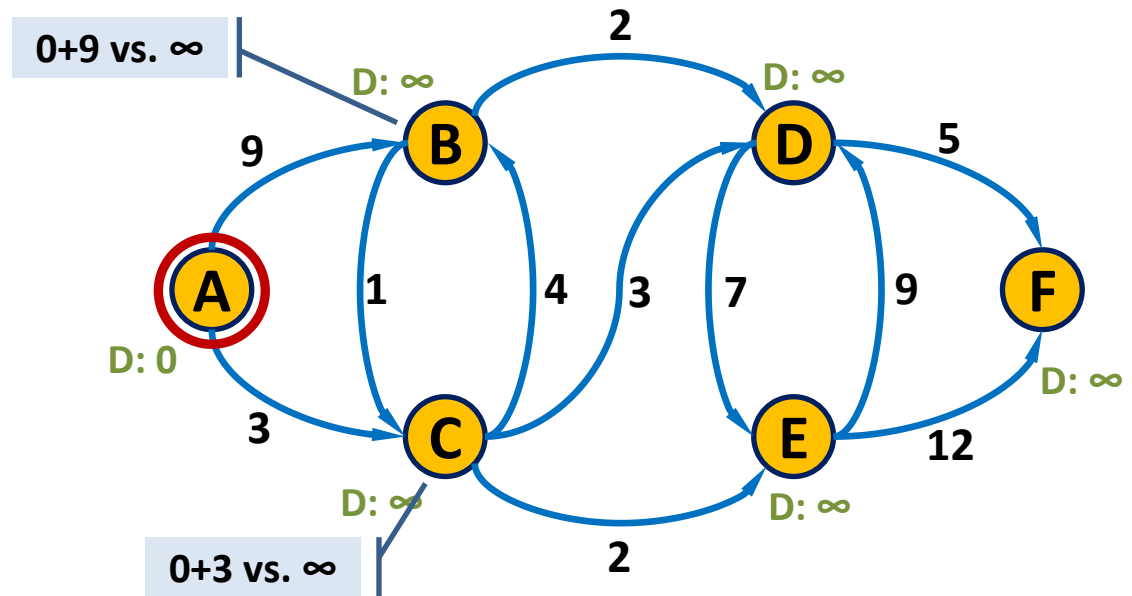

Dijkstra's algorithm

- Update D
- Record path

A	B	C	D	E	F
0	∞	∞	∞	∞	∞
0	9	3	∞	∞	∞

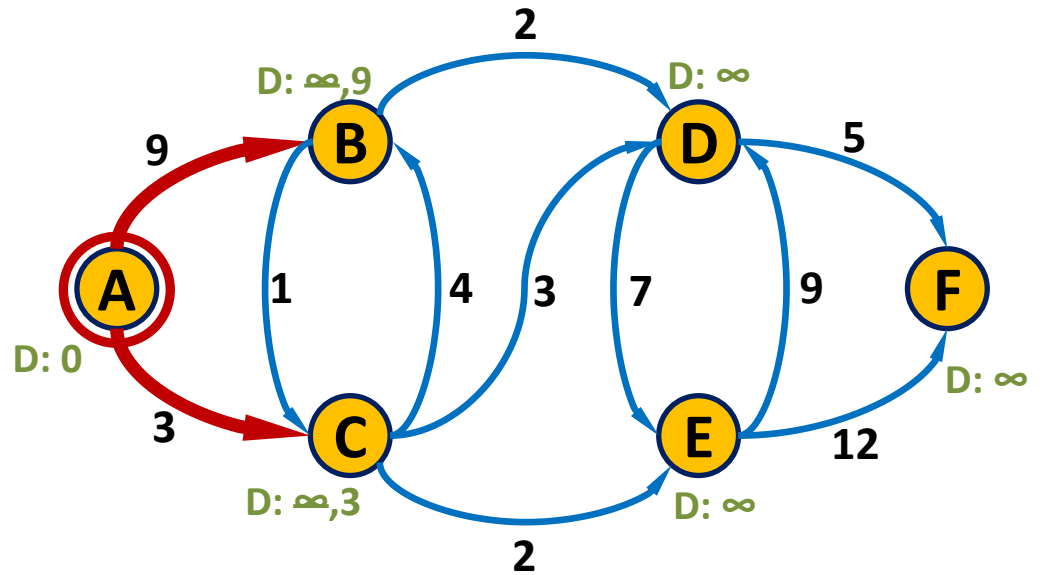

Dijkstra's algorithm

- Mark A as visited ...

A	B	C	D	E	F
0	∞	∞	∞	∞	∞
0	9	3	∞	∞	∞

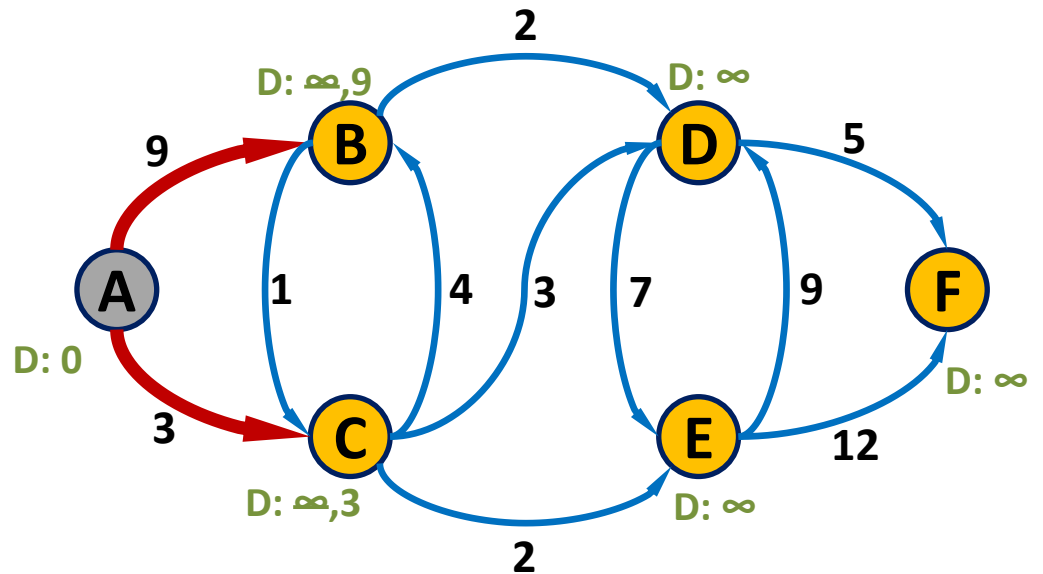

Dijkstra's algorithm

- Mark C as current (unvisited node with smallest D)

A	B	C	D	E	F
0	∞	∞	∞	∞	∞
0	9	3	∞	∞	∞

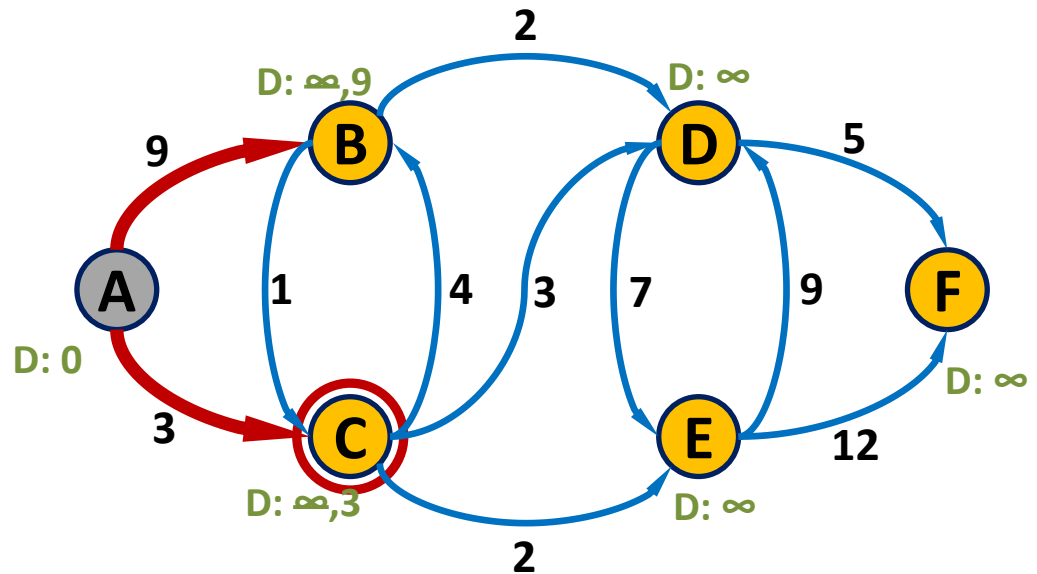

Dijkstra's algorithm

- Check unvisited neighbors of C

A	B	C	D	E	F
0	∞	∞	∞	∞	∞
0	9	3	∞	∞	∞

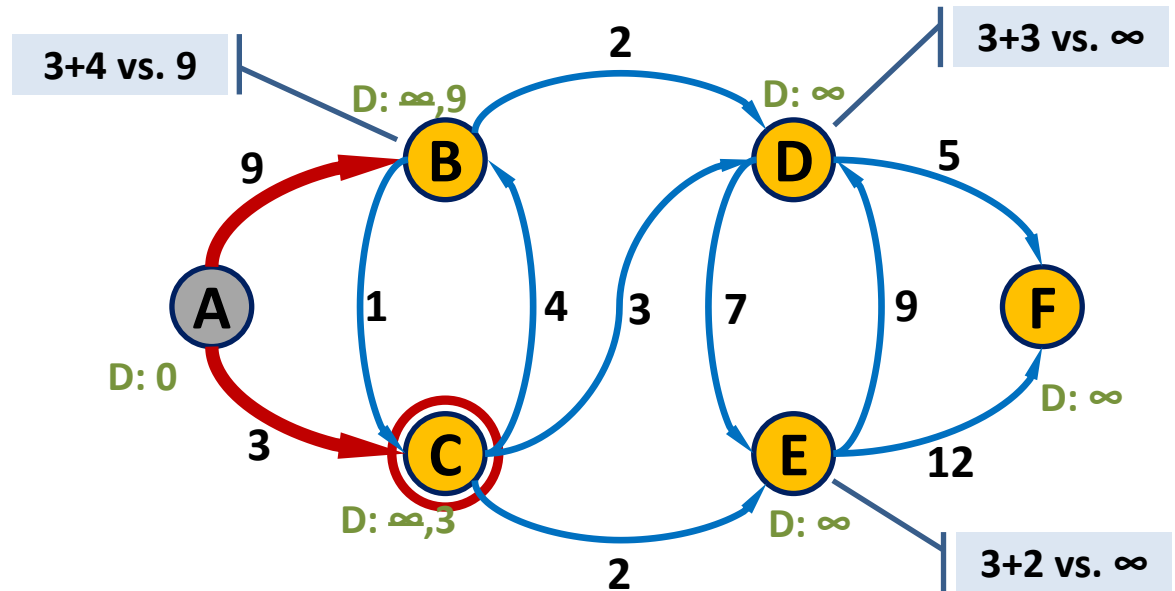

Dijkstra's algorithm

- Update distance
- Record path

A	B	C	D	E	F
0	∞	∞	∞	∞	∞
0	9	3	∞	∞	∞
	7	3	6	5	∞

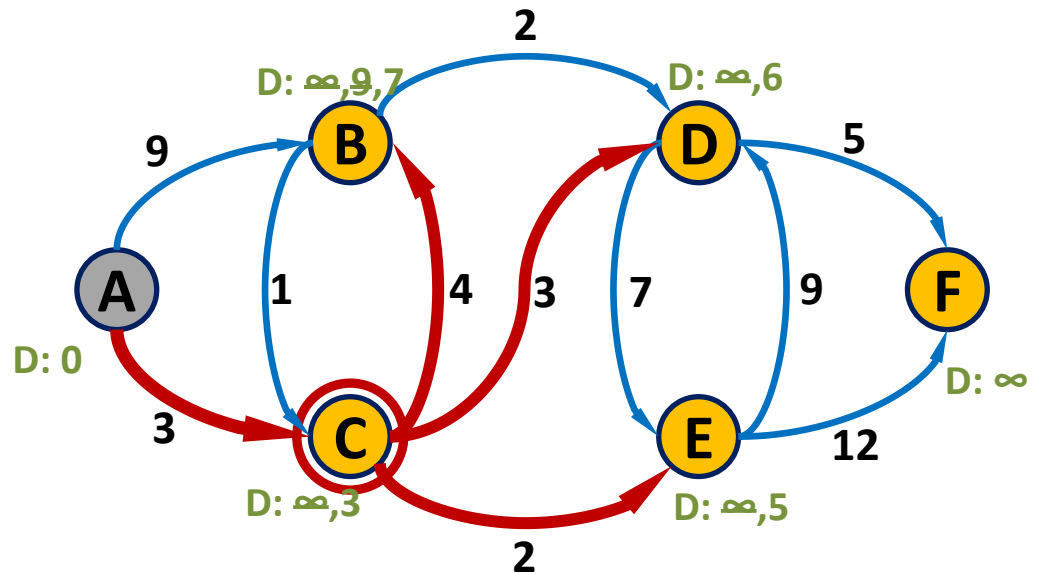

Dijkstra's algorithm

- Mark C as visited
- Note: Distance to C is final!!

A	B	C	D	E	F
0	∞	∞	∞	∞	∞
0	9	3	∞	∞	∞
	7	3	6	5	∞

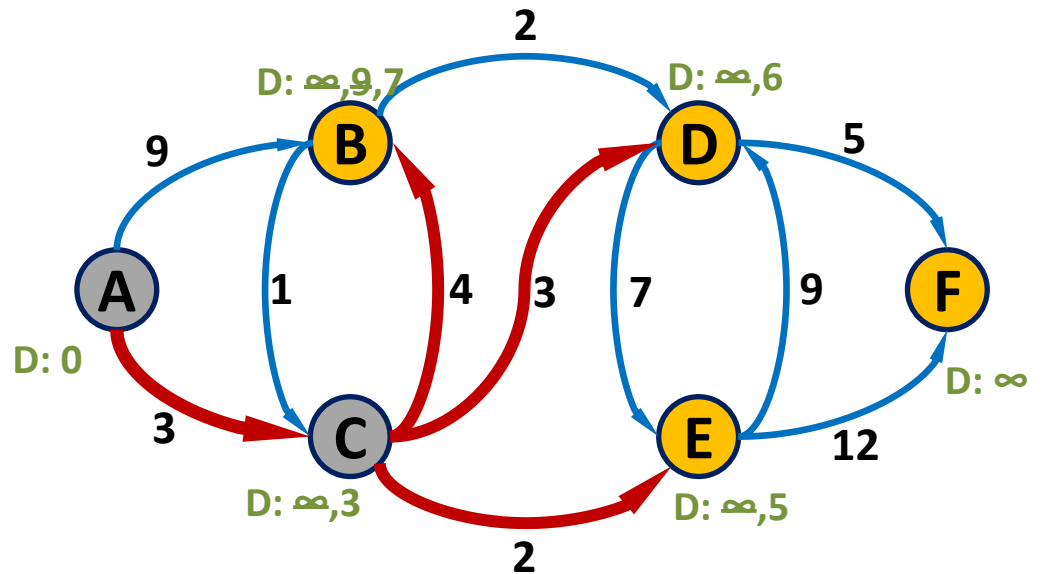

Dijkstra's algorithm

- Mark E as current node
- Check unvisited neighbors of E

A	B	C	D	E	F
0	∞	∞	∞	∞	∞
0	9	3	∞	∞	∞
	7	3	6	5	∞

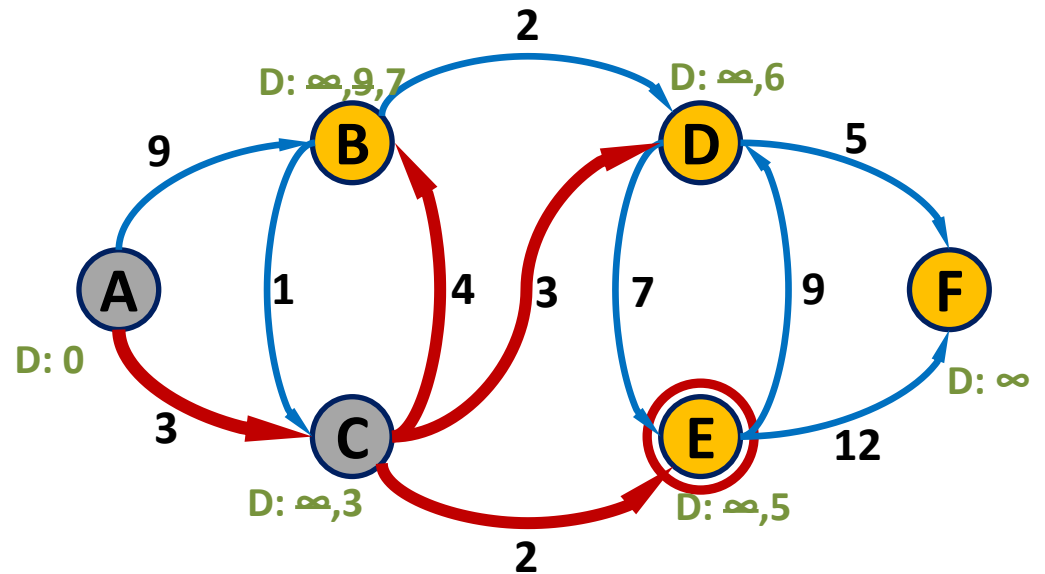

Dijkstra's algorithm

- Update D
- Record path

A	B	C	D	E	F
0	∞	∞	∞	∞	∞
0	9	3	∞	∞	∞
	7	3	6	5	∞
	7		6	5	17

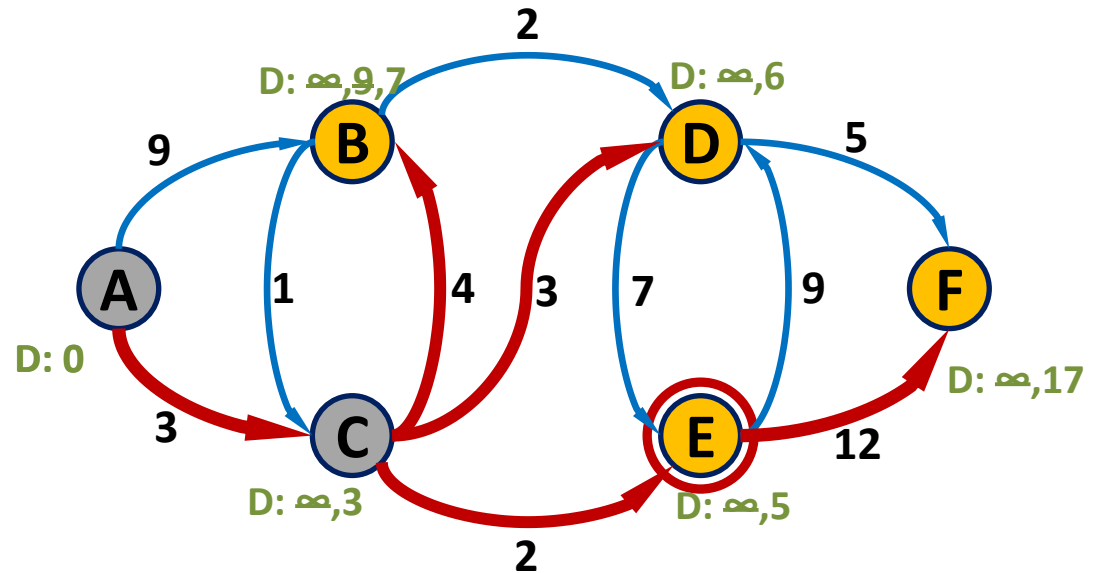

Dijkstra's algorithm

- Mark E as visited

A	B	C	D	E	F
0	∞	∞	∞	∞	∞
0	9	3	∞	∞	∞
	7	3	6	5	∞
	7		6	5	17

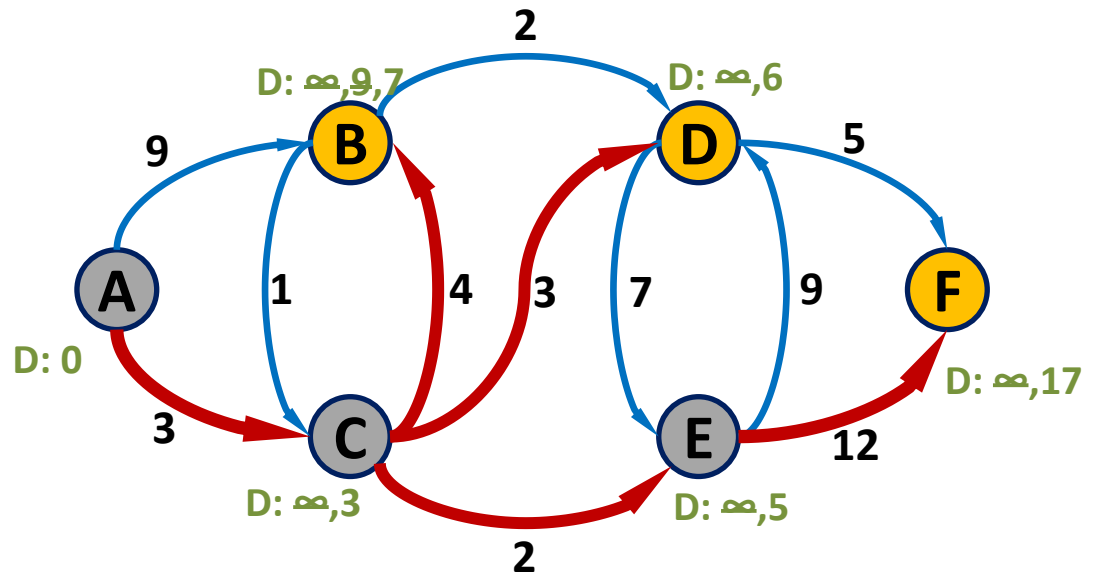

Dijkstra's algorithm

- Mark D as current node
- Check unvisited neighbors of D

A	B	C	D	E	F
0	∞	∞	∞	∞	∞
0	9	3	∞	∞	∞
	7	3	6	5	∞
	7		6	5	17

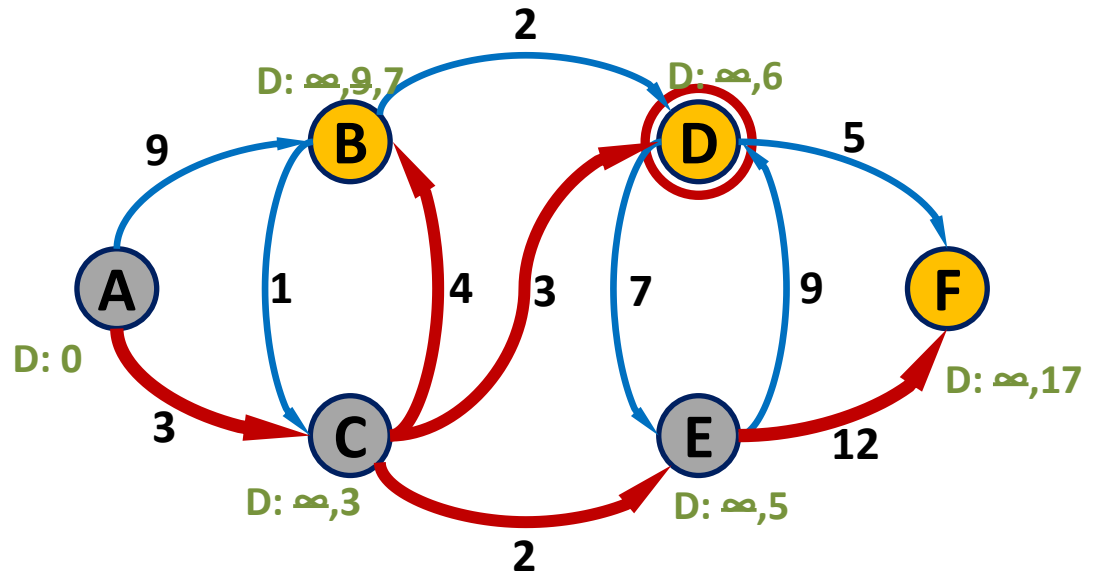

Dijkstra's algorithm

- Update D
- Record path (note: path has changed)

A	B	C	D	E	F
0	∞	∞	∞	∞	∞
0	9	3	∞	∞	∞
	7	3	6	5	∞
	7		6	5	17
	7		6		11

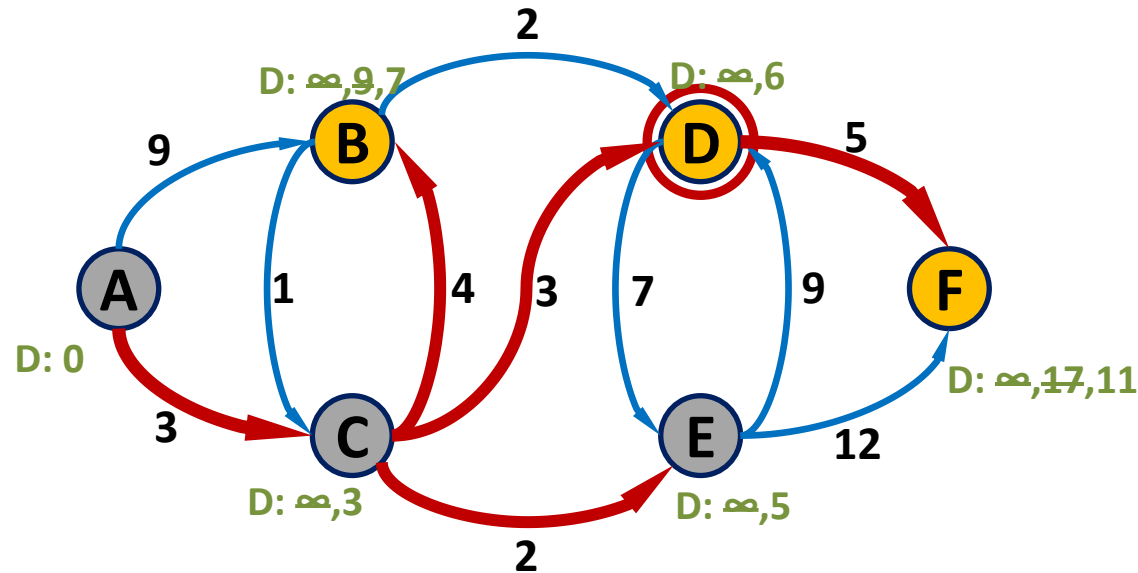

Dijkstra's algorithm

- Mark D as visited

A	B	C	D	E	F
0	∞	∞	∞	∞	∞
0	9	3	∞	∞	∞
	7	3	6	5	∞
	7		6	5	17
	7		6		11

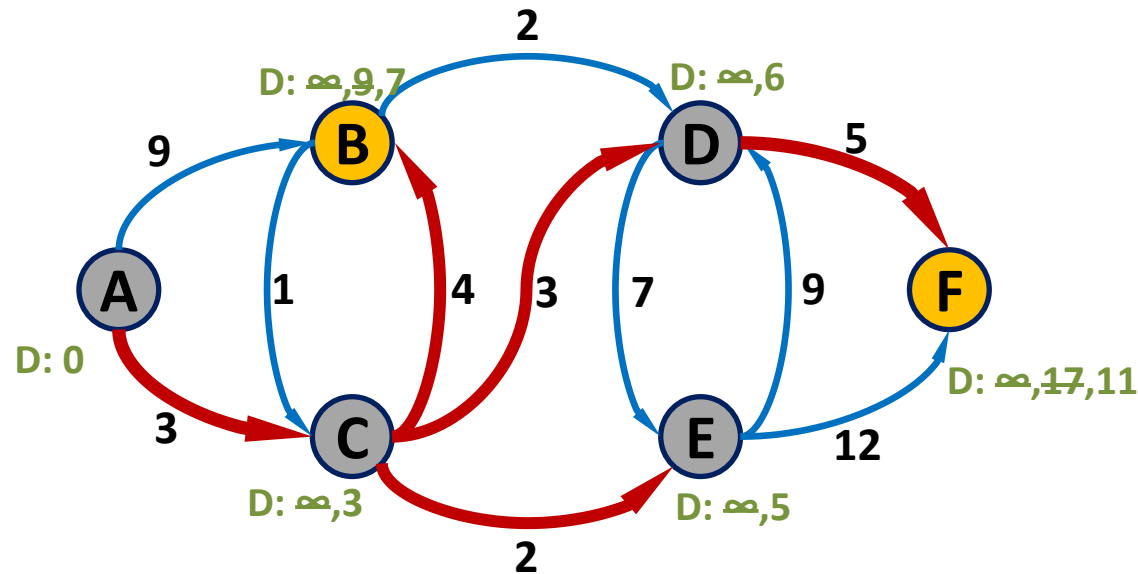

Dijkstra's algorithm

- Mark B as current node
- Check neighbors

A	B	C	D	E	F
0	∞	∞	∞	∞	∞
0	9	3	∞	∞	∞
7	3	6	5	∞	
7		6	5	17	
7		6		11	

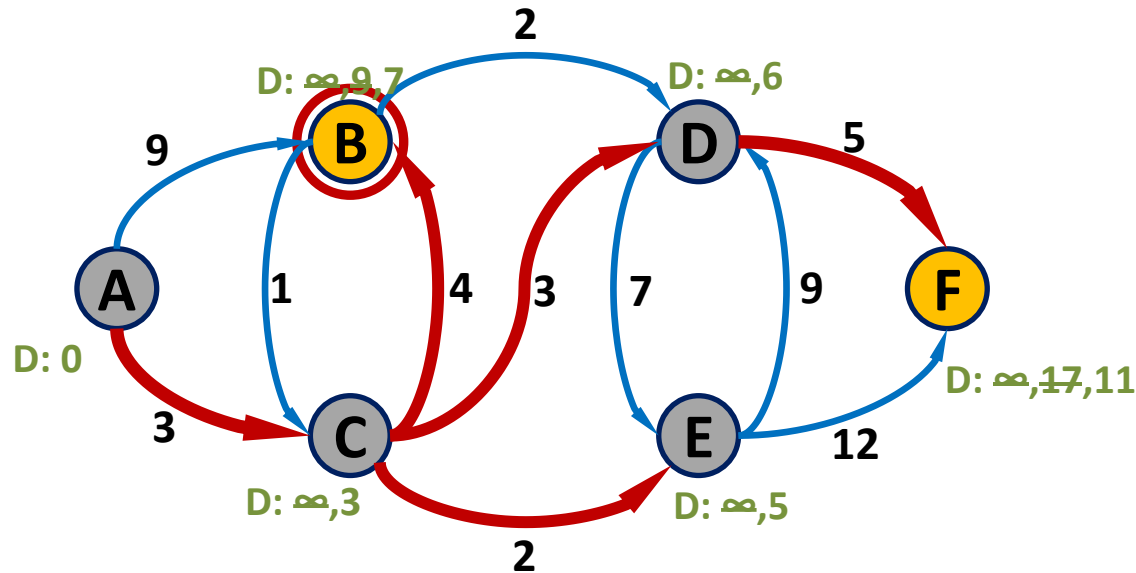

Dijkstra's algorithm

- No updates..
- Mark B as visited

A	B	C	D	E	F
0	∞	∞	∞	∞	∞
0	9	3	∞	∞	∞
	7	3	6	5	∞
	7		6	5	17
	7		6		11
	7				11

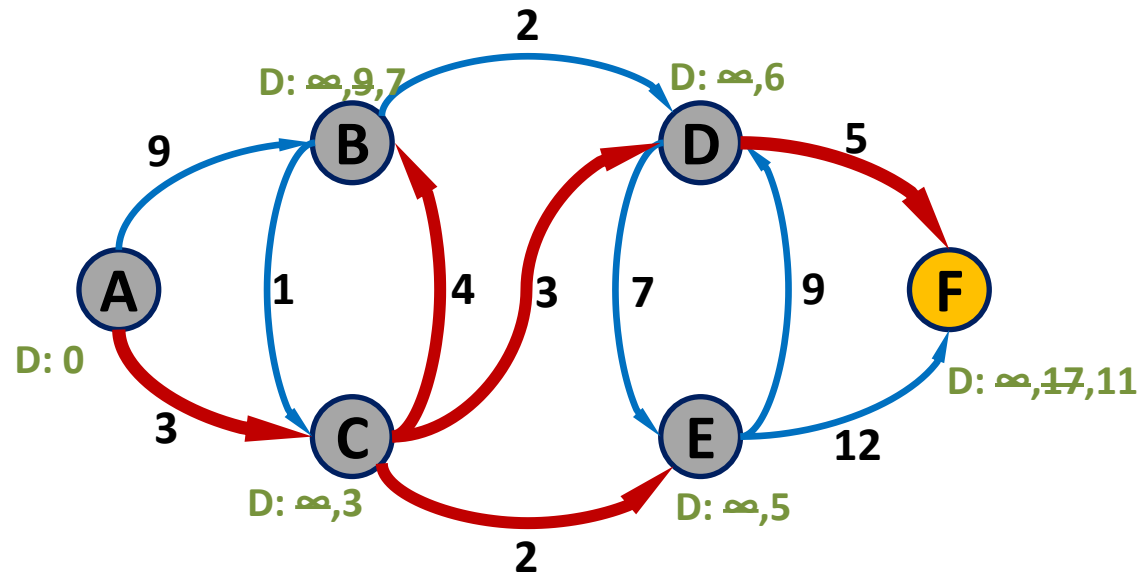

Dijkstra's algorithm

- Mark F as current

A	B	C	D	E	F
0	∞	∞	∞	∞	∞
0	9	3	∞	∞	∞
	7	3	6	5	∞
	7		6	5	17
	7		6		11
	7				11

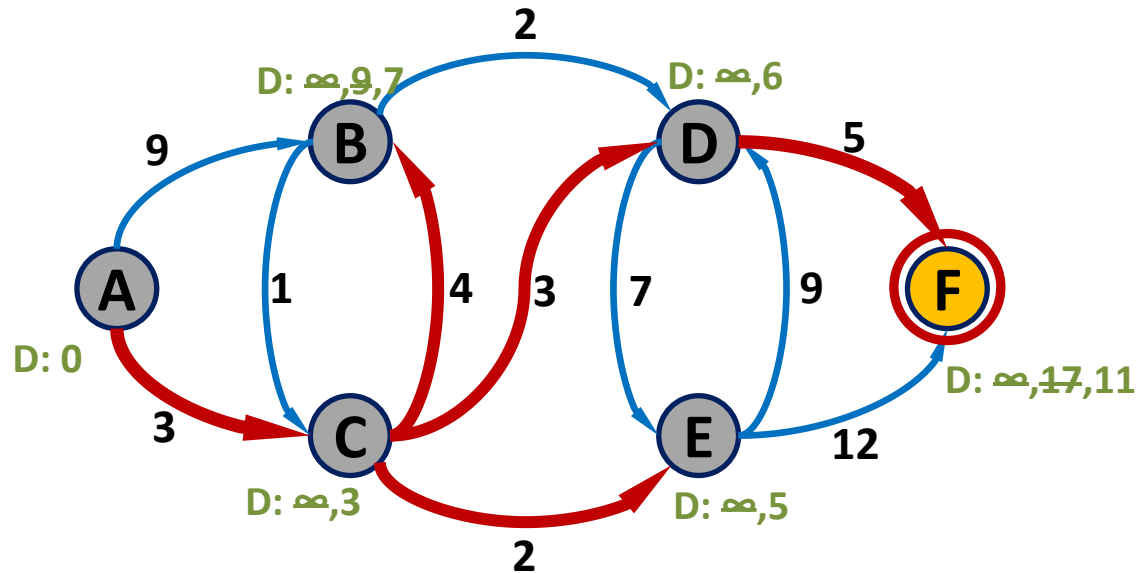

Dijkstra's algorithm

- Mark F as visited

A	B	C	D	E	F
0	∞	∞	∞	∞	∞
0	9	3	∞	∞	∞
	7	3	6	5	∞
	7		6	5	17
	7		6		11
	7				11
					11

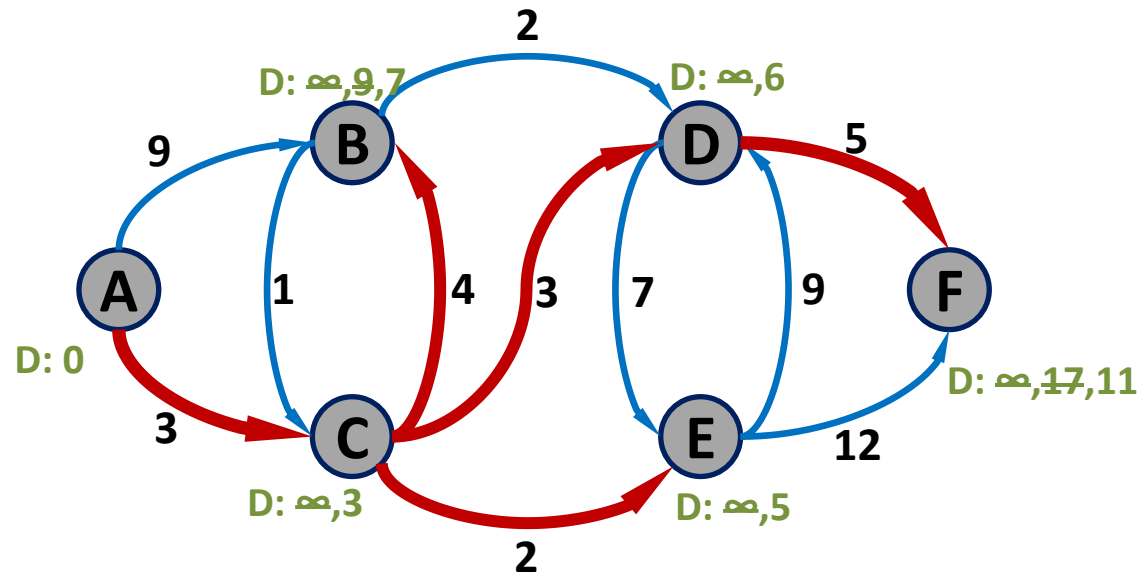

We are done!

- We now have:
 - Shortest path from A to each node (both length and path)

A	B	C	D	E	F
0	∞	∞	∞	∞	∞
0	9	3	∞	∞	∞
	7	3	6	5	∞
	7		6	5	17
	7		6		11
	7				11
					11

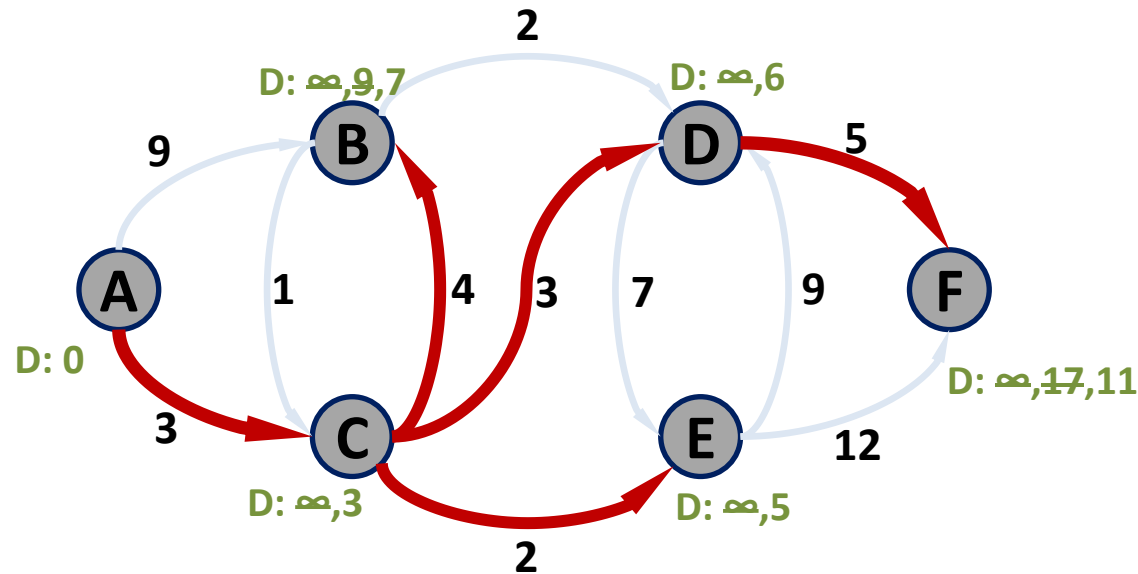

We are done!

- We now have:
 - Shortest path from A to each node (both length and path)
 - **Minimum spanning tree**

A	B	C	D	E	F
0	∞	∞	∞	∞	∞
0	9	3	∞	∞	∞
	7	3	6	5	∞
	7		6	5	17
	7		6		11
	7				11
					11

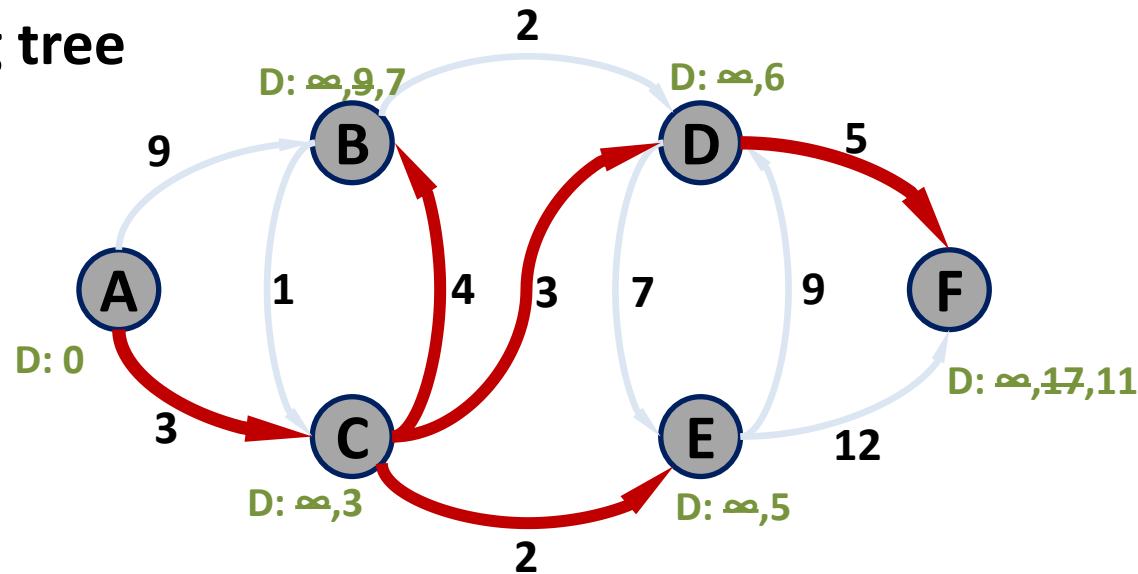

Will we always get a tree?
Can you prove it?

How would you represent a network
in your python code?

Computational Representation of Networks

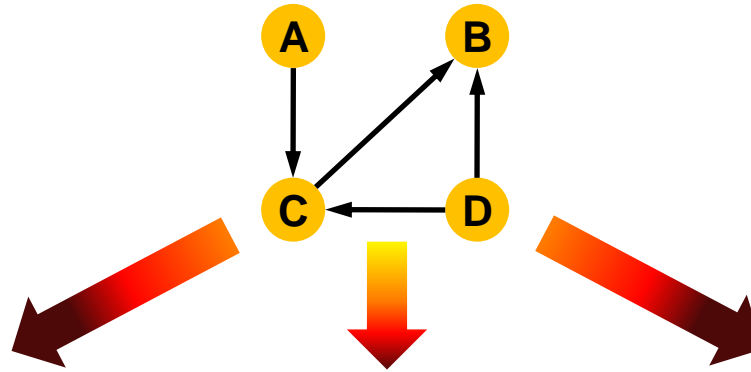

List of edges:

(ordered) pairs of nodes

[(A,C) , (C,B) ,
(D,B) , (D,C)]

Connectivity Matrix

	A	B	C	D
A	0	0	1	0
B	0	0	0	0
C	0	1	0	0
D	0	1	1	0

Object Oriented

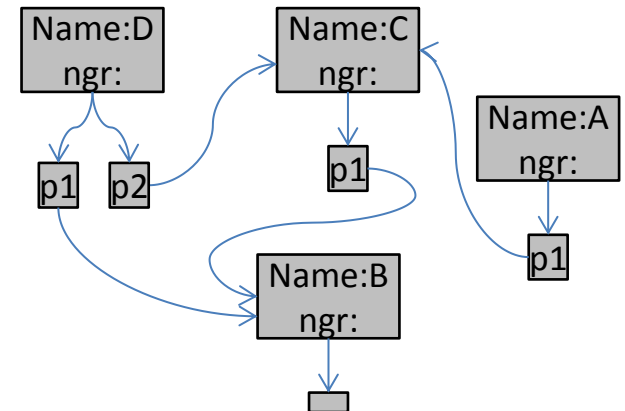

- Which is the most useful representation?

Why networks?

Networks as models

Simple, visual representation
of complex systems

Focus on organization
(rather than on components)

Discovery
(topology affects function)

Predictive models

Diffusion models
(dynamics)

Networks as tools

Problem representation
(more common than you think)

Algorithm development

